



## HV/HVL PUMPS

*Vertical pumps*



# INSTALLATION MANUAL, USE AND MAINTENANCE

Translation of the original instructions

**(SAFETY INSTRUCTIONS)**

## INDEX

<b>1. INTRODUCTION.....</b>	<b>5</b>
1.1 General.....	5
1.2 Purpose of the Manual .....	5
1.3 Safety Alert Symbols.....	5
1.4 Qualification and training of operators.....	5
1.5 Explosion Hazard Environment.....	5
<b>2. INSTALLATION.....</b>	<b>6</b>
2.1 General Safety Warnings .....	6
2.1.1 <i>Premise on the hazard</i> .....	6
2.1.2 <i>Hazard information</i> .....	6
2.2 Receipt and Inspection.....	7
2.3 Storage .....	7
2.4 Installation and Fixing .....	8
2.5 Hydraulic system .....	9
2.6 Suction and delivery hose connections .....	9
2.7 Control tools .....	9
2.8 Motor Connection.....	10
<b>3. SERVICE.....</b>	<b>11</b>
3.1 Use and Safety .....	11
3.2 First start-up.....	11
3.3 Temperature .....	11
3.4 Before Starting.....	12
3.5 Start-up .....	12
3.6 Optimal conditions of use.....	12
3.7 Shutdown .....	12
3.8 Long Pump Inactivity .....	13
3.9 Noise Level.....	13
<b>4. MAINTENANCE.....</b>	<b>13</b>
4.1 General Provisions.....	13
4.2 Inspections .....	14

<b>4.3 HVL Pump Main Parts</b> .....	<b>15</b>
4.3.1 Exploded view and Section.....	15
4.4 HVL Pump Disassembly .....	16
4.4.0 Procedure before disassembly.....	16
4.4.1 Disassembling the delivery pipe.....	16
4.4.2 Motor Disassembly.....	16
4.4.3 Disassembling the pump casing.....	17
4.4.4 Disassembly the shaft with Bracket.....	18
4.4.5 Disassembling the shaft from the Bracket.....	19
4.4.6 Different configuration between versions .....	19
4.5 HVL Mounting .....	19
4.5.1 Warnings .....	19
4.5.2 Mounting Shaft with Bracket.....	19
4.5.3 Pump Body Assembly.....	20
4.5.4 Discharge pipe assembly.....	20
4.5.6 Motor Mounting .....	20
<b>4.6 HV Pump Main Parts</b> .....	<b>21</b>
4.6.1 Exploded view and Section.....	21
4.7 HV Pump Disassembly.....	21
4.7.0 Procedure before disassembly.....	21
4.7.1 Disassembling the delivery pipe.....	22
4.7.2 Disassembling the pump casing.....	22
4.7.3 Motor and shaft disassembly.....	23
4.8 HV Mounting.....	24
4.8.1 Warnings .....	24
4.8.2 Shaft Mounting with Motor .....	24
4.8.3 Pump casing assembly.....	25
4.8.4 Discharge Pipe Assembly.....	25
4.9 Tightening Torques.....	25
<b>5. TROUBLESHOOTING</b> .....	<b>26</b>
<b>6.SPARE PARTS</b> .....	<b>26</b>
6.1 How to Order Spares .....	26
<b>7. DATA</b> .....	<b>27</b>
7.1 Characteristic curves.....	27
7.2 Dimensions .....	28
7.2.1 HV Monoblock Verticals Pumps .....	28
7.2.2 HVL Vertical with Coupling Pumps.....	29
7.3 Technical data and limitations .....	31

**8. WARRANTY AND REPAIR.....32**

8.1 Warranty ..... 32

8.2 Parts Returns and Repairs..... 33

8.3 Declaration of remediation (facsimile)..... 33

8.4 CE Certificate for HV-HVL Series Pumps..... 34

## 1. INTRODUCTION

### 1.1 General

This manual refers to the HV mono block and HVL with coupling model vertical pump family. The pumps of this family are made of thermoplastic material (Polypropylene or PVDF) and in different sizes. The dimensions and powers available are described in paragraph 7.0.

### 1.2 Purpose of the Manual

The primary purpose of the manual is to ensure that the installation, use and maintenance of the pumps are carried out correctly and safely by the various operators in charge of these operations. The document also provides useful information to the customer for diagnosing problems, finding spare parts and accessing the repair service offered by GemmeCotti s.r.l.

### 1.3 Safety Alert Symbols



This symbol indicates possible hazards induced by the presence of electric fields, contacts or wires with electric voltage.



The exclamation mark signs in this manual indicate a situation of particular importance that requires operator attention. In particular, they are useful indications for the correct operation and prevention of possible damage to the devices.



This symbol indicates a hazard or situation that requires the operator's full attention. It is essential to follow the instructions provided in the margin of this symbol and proceed with the utmost caution. It is necessary to inform all operators and/or users that the rules indicated prevent accidents.

### 1.4 Qualification and training of operators



Personnel in charge of the installation, operation and maintenance of the pumps must be qualified to perform the operations indicated in this manual. GemmeCotti cannot be held responsible for the insufficient level of preparation and training of the customer's staff and for the fact that they have not been informed about the contents of this manual. It is essential that operators in charge of the installation, operation and maintenance of the pump always provide this manual. Keep this manual in a safe place for future reference.

### 1.5 Explosion Hazard Environment

The pumps described in this manual may not be used in explosive environments. For this type of use, special pumps built by GemmeCotti with special materials and devices are required. The customer who intends to use special pumps in this type of environment must consult the GemmeCotti technical

department for a correct choice of the item.

The pump models, built by GemmeCotti, for this type of application can be distinguished by the acronym EM-T.

The model, EM-T pumps made of PP or PVDF can only be installed in ATEX zone 2 II3G areas. Refer to paragraph 2.7.1. for more information.



**IT SHOULD BE NOTED THAT THE CLASSIFICATION OF THE AREA (REF. ATEX DIRECTIVE 2014/34/EU ex 94/9/EC) FOR ENVIRONMENTS WITH DANGER OF EXPLOSION MUST BE MADE BY THE CUSTOMER AND COMMUNICATED TO GEMMECOTTI FOR THE CHOICE OF THE TYPE OF PUMP SUITABLE FOR OPERATING IN THESE ENVIRONMENTS.**

It is also the customer's responsibility to install the pump correctly in accordance with the requirements of the Directive

## 2. INSTALLATION

### 2.1 General Safety Warnings <sup>1</sup>

All references made to pumps are to be considered applicable to systems using these pumps unless otherwise specified.

#### 2.1.1 Premise on the hazard



**WARNING:** Failure to follow the directions in this manual or improper use of the equipment by unqualified and unauthorized personnel could result in serious personal injury or death and damage to products and property!

The technical assistance service is at your complete disposal; for any doubts or problems you can contact us by phone at +39 02 964.60.406 or write an email to [info@gemmecotti.com](mailto:info@gemmecotti.com). It is strongly recommended that you keep GemmeCotti's written answer.

#### 2.1.2 Hazard information



For the safety of the operators involved in installation operations, it is necessary to use protective clothing and personal protective equipment approved according to current legal provisions (i.e. safety glasses, gloves and insulating and protective footwear against crushing).



These pumps have been designed and built for use in specific conditions and within defined limits. Use outside of these specifications must be agreed and approved by GemmeCotti's technical service. **It must be borne in mind that if pumps are used outside of their technical specifications, the CE Certification and Warranties are void. Furthermore, if the pump is used outside the technical specifications communicated in the quote phase and confirmed with our order confirmation, the user assumes all responsibility for the CE certification of the product.**



The pump should only be used in the applications specified in the order for which GemmeCotti has selected the model, materials of construction and tested the pump to meet its specifications. For any use other than what is communicated with the order, a written request must always be made to the technical department of GemmeCotti which in turn will respond in writing.



No warranty is provided for repairs or alterations made to the product by users or by third parties not

<sup>1</sup> Failure to follow the warnings provided may void the Pump Certification and Warranty

specifically authorized by GemmeCotti.

Always stop the pump before touching it or carrying out any work on it or in the installation circuit. The pump must be emptied of the pumped liquid, and thoroughly decontaminated with water before carrying out any intervention.



Make sure that the mains power supply to which the pump will be connected is of adequate power and has the correct protective devices (i.e. earthing, circuit breaker).

Always disconnect the electrical supply before working on the pump for maintenance or replacement of parts.



Always keep a fire extinguisher in the vicinity of the pump installation.

Always take extreme care when performing maintenance tasks on pumps and related circuits when they are used with hazardous liquids.



The use of an electric starter is recommended. A simple switch may not be enough to start and stop the electric motor connected to the main power line. An appropriate starter:

- it allows you to prevent accidental starting after a failed starting attempt;
- provides a safe switch, protected against water;
- protects the electric motor against overloads from short circuits (a fuse only protects the wires);
- resists overload starting on the motor, preventing dangerous electric arcs and premature wear of the electrical contacts.

## 2.2 Receipt and Inspection

Although all precautions have been taken before packing, we recommend that you carefully check the material received. Review all items on the packing list. Make a written report immediately for any damage or deficiencies attributable to the carrier and/or GemmeCotti.

**ATTENTION:** Check the nameplate data of the pump received and compare them with those relating to your purchase order. Also compare the dimensional correspondence (through the overall drawing provided to each customer)

If the pump has been supplied with the motor, remove the protective shield of the motor fan and try rotating the motor shaft by hand. If you feel a strong resistance to rotation or if you hear abnormal noises, call your trusted dealer or directly the GemmeCotti assistance service.

## 2.3 Storage



If the pump is stored in stock, make sure that this is done in a non-humid and sheltered location; always use the original packaging or equivalent protection. If the pump is left in storage for very long periods and/or in particularly humid environments, the use of hygroscopic substances (silica gel) is recommended to prevent damage.



Do not remove the flange protections until the time of installation and if not already closed, plug the holes in the intake/delivery and air connection manifolds to prevent the intrusion of foreign bodies.



It is warned that prolonged storage time of the pumps may result in:

- degradation of the motor insulation due to moisture absorption
- Degradation of gaskets

## 2.4 Installation and Fixing



GemmeCotti s.r.l. cannot be held responsible for damage to persons or objects caused by improper installation or carried out by unqualified personnel.

Install the pump in a location that allows for easy service.



The motor/pump unit must be fixed on a rigid structure that allows the entire structure to be supported. Make sure the pump is fixed on a plane. Where deemed necessary, use "bumpers" to reduce vibrations towards the fixing surface.



**WARNING:** the pump must be installed perfectly vertical and the plate must be fixed to a suitable support placed above the well in which it is inserted.

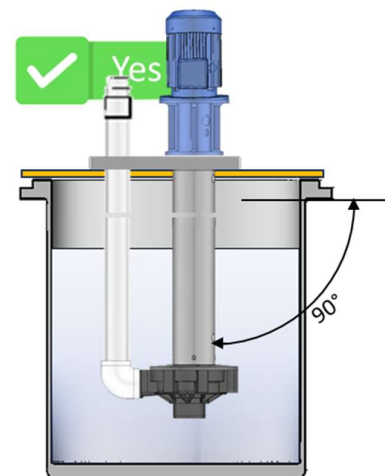
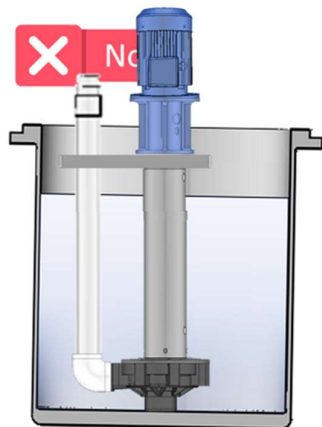
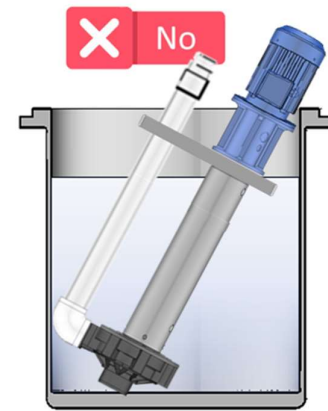
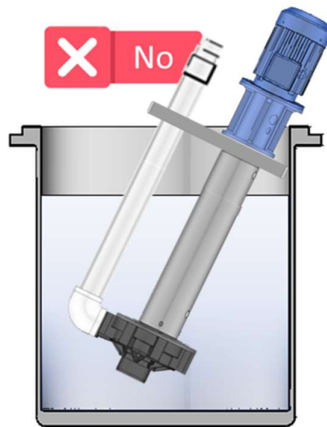

## 2.5 Hydraulic system

The pump is generally part of a hydraulic system that can include a number of components such as valves, equipment, filters, expansion joints, tools, etc. The way the implant is performed and the placement of its components has a great influence on the operation and life of the pump.



It is advisable to wash the new systems internally before installing the pump to remove any processing residues to prevent them from entering it and damaging it

## 2.6 Suction and delivery hose connections <sup>2</sup>



Place the pump inside the well. The liquid level should never be

- below the hole in the lower part of the column
- above the hole at the top of the column, near the plate

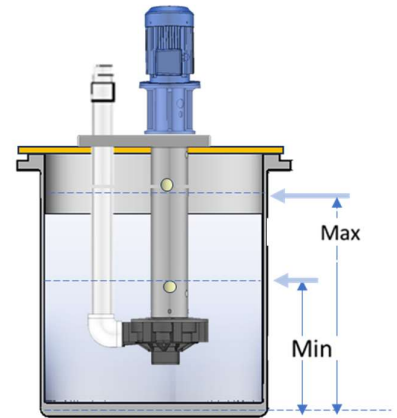

Always use tubes as short as possible, limiting bends to a minimum and ensuring the largest possible bend radii. Avoid air pockets that may arise in long pipework. Do not create siphons before the pump is suctioned.

The piping should be supported and kept in line independently of the pump, up to its connections, so as not to burden it.



The suction line must be cleaned and/or equipped with a filter to protect the impeller from damage due to slag, or other foreign particles, especially when the system is first started. Never pair metal piping onto plastic pumps.



Tightening the pipes on plastic pumps must be carried out without the use of tools. Make sure the connections are carefully tightened otherwise the suction capacity will be reduced.



A pressure gauge should be installed in both suction and discharge piping. Installing pressure gauges will allow the operator to easily check the correct operation of the pump in relation to the required operating point. In the event of cavitation or other malfunctions, noticeable pressure fluctuations will be observed.

## 2.7 Control tools



Depending on the importance of the pumping circuit, it may be useful to maintain strict control over the performance and condition of the process. The use of pressure measuring instruments on the suction and discharge circuits may be recommended.

The measurement of the electrical power absorbed by the motor can also be measured by means of the use of a wattmeter.

If the temperature of the pumped liquid can be a critical element, insert a thermometer into the circuit, preferably on the suction line.

<sup>2</sup> Failure to follow the warnings provided may void the warranty terms on the pumps supplied.

These control tools can warn you of any abnormal pump operating situations such as: accidentally closed valves, missing liquid, overloads, etc.

## 2.8 Motor Connection



Check that the voltage and frequency on the motor label match those of the mains supply you are to use. Never connect the electric motor directly to the main line but protect the dedicated line with a suitable main switch with the appropriate protections for safety and overloads.



Electrical connections should always be made by a qualified experienced electrician.

The motors supplied must be powered with three-phase voltages or, if required by the customer, single-phase. The type of connection in three-phase motors can be star (Y) or delta ( $\Delta$ ) according to the 380 or 220 VAC power supply line (see figure 1).

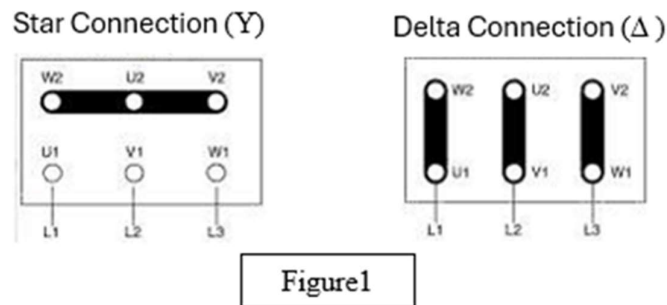

Make sure that the direction of rotation of the motor is the one specified on<sup>3</sup> the pump body and possibly indicated by an adhesive arrow placed on the fan cover of the motor itself; to reverse the direction of rotation, simply reverse two of the three inlet lines (e.g. L1 with L2) in three-phase motors.

To test the direction of rotation follow these instructions:



- wear approved personal protective equipment (i.e. goggles, gloves)
- ensure that the conditions of use comply with the pump specifications (see paragraph 7)
- Install the pump in the hydraulic system
- Fully open the intake and exhaust valve
- let the liquid flow inside the pump. It is recommended to carry out this test with an inert liquid such as water.
- Never allow the pump to run dry
- power the motor only for one or two seconds to observe the direction of rotation that complies with the arrow on the pump body itself.

**NOTE:** A pump that turns in reverse will still pump but with a flow and pressure much lower than the data on the nameplate.

<sup>3</sup> Proceed as indicated in the following steps.

## 3. SERVICE

### 3.1 Use and Safety

#### WARNING:

Dangerous or risky practices can cause serious injury or death to persons or serious property damage, it is therefore essential to ensure compliance with all safety and correct use warnings provided in this manual.



Always check that the fluid being pumped is compatible with the materials of construction of the pump. For any clarification, contact the technical office of GemmeCotti.



In the case of use for pumping aggressive, toxic or dangerous liquids, it is generally necessary to install on the pump an adequate protection for containment, collection and the warning of the dangerous product in the event of a spill: e.g. DANGER OF POLLUTION, CONTAMINATION, INJURY AND/OR DEATH.



Never restrict your intake. Narrowing of the suction is responsible for pump cavitation, which leads to loss of efficiency and rapid wear. Narrowing of the discharge is not advisable, reductions in the flow rate, if required, can be obtained by means of a valve installed on the delivery pipe.



Never loosen the pump connections while it is under pressure.



Do not start and/or run the pump if there are traces of leaks in the circuit.

The operating temperatures must be such as to comply with the characteristics of the construction materials used in the pump:

- **0-60 °C** polypropylene (PP) design
- **0-80 °C** PVDF design



**NEVER RUN THE PUMP DRY** (N.B. the design of the pump does not allow dry operation as this will irreparably damage the internal components of the pump)

- An accidental failure can generate splashes up to a considerable distance.
- In case of vibrations or abnormal noises, stop the pump immediately.
- Do not pump flammable liquids.
- Do not touch the pump while it is running.
- Before touching the motor or bracket, turn off the power.

### 3.2 First start-up



Fill the pump with water (if compatible with the process liquid) or with the liquid to be pumped before starting the pump. This will protect the pump sleeves and shaft against dry running. **NEVER RUN THE PUMP DRY** as serious damage can be caused by lack of lubrication to the internal components of the pump.

### 3.3 Temperature



Increasing the temperature of the fluid being handled may damage the pump and/or the system pipes and may cause a situation of serious danger to people in the vicinity. Avoid sudden changes in

temperature and do not exceed the temperatures specified in the order. See the temperature values of the pump construction materials in section 3.1.

### 3.4 Before Starting

Be sure that the pump is installed in accordance with the instructions provided in section 2 above.



When the pumping station is new, the system should be filled with water (or other inert liquid) to check for leaks. **IF THE PUMP IS MOUNTED ABOVE THE HEAD, IT MUST BE PRIMED, I.E. FILLED WITH LIQUID, AND THE SUCTION PIPE MUST BE KEPT FULL OF LIQUID BEFORE START-UP**



**WARNING: ALL PUMPS ARE TESTED WITH WATER, IT IS THEREFORE POSSIBLE THAT THERE ARE SMALL WATER RESIDUES; IF THE LIQUID TO BE PUMPED IS INCOMPATIBLE WITH WATER or if the SYSTEM where the pump will be installed MAY BE DAMAGED by the presence of water. IT IS NECESSARY TO DRY THE PUMP THOROUGHLY WITH AIR AT A TEMPERATURE NOT EXCEEDING 35°C.**

### 3.5 Start-up

Start the electric motor and open the delivery duct gradually until the desired flow is achieved.

The pump may not run for more than two to three minutes with the discharge circuit closed. A longer period may cause serious damage to the pump.

If the pressure indicated by the output control tools does not increase, turn off the pump immediately and release the pressure gradually.

Repeat the pump installation operations as per paragraph 2.

If during the start-up phase there are changes in the flow rate, density, temperature or viscosity of the liquid, stop the pump and contact the technical assistance service of GemmeCotti s.r.l..

### 3.6 Optimal conditions of use

Continuous operation at maximum performance (maximum pressure/flow rate) can lead to premature pump wear. As a good practice, we recommend using the pump at half its maximum flow rate (see section on technical data).



The flow rate and head of the pump refer to pumping water at room temperature. If liquids are to be pumped at high temperatures or high viscosities and densities, the performance must be correspondingly reduced. The HCO series pumps work well with liquids having viscosities up to 100 CPS<sup>4</sup> and specific weights up to 1.9 kg/dm<sup>4</sup>. **IN ANY CASE, BOTH VISCOSITY AND SPECIFIC GRAVITY MUST BE COMMUNICATED DURING THE REQUEST FOR QUOTATION PHASE, THE ELECTRIC MOTOR IS SELECTED FOR THE VISCOSITY AND SPECIFIC GRAVITY COMMUNICATED, IF THEY ARE HIGHER, THE POWER OF THE MOTOR MAY BE INSUFFICIENT.**

### 3.7 Shutdown

Normally the pump should only be stopped after the outlet valve has closed. If the suction valve is closed earlier, cavitation of the pump can occur.

In the event that the suction is flooded, close the valve after stopping the pump.

<sup>4</sup> The values quoted are for guidance only and may vary within the family of HCO series pumps.



In some cases the pump could be used to empty tanks or cisterns, in these cases it may happen that the liquid stops flowing into the pump while it is still working. In these cases, a pump that operates without liquids (and therefore dry) can be seriously damaged if it is not immediately stopped. For this type of use, it is recommended to use automatic stop devices or the constant presence of an operator who can promptly stop the pump.

### 3.8 Long Pump Inactivity



If the pump remains stationary for a long period, before proceeding with the stop, it is advisable to circulate water in the circuit for several minutes, thus avoiding the risk of internal encrustations or precipitation of solid parts. Then drain the liquid into the pump. Freezing of the liquid inside the pump may cause damage. In any case, check whether the pumped liquid reacts with water. In this case, contact GemmeCotti to verify an alternative solution.

In cases where the pump is temporarily removed from the system and stored, the instructions given in section 2.3 "Storage" must be followed.

### 3.9 Noise Level

In some circumstances, for example when the pump works with high pressure and low flow rate, the noise increases and can be annoying to personnel working nearby. In this case, it is possible to intervene with:



- earplugs;
- protective ear defenders approved for nearby personnel;
- soundproofing devices for the pump. In these cases, make sure that the ventilation of the motor is guaranteed.

## 4. MAINTENANCE

### 4.1 General Provisions



During the warranty period, no extraordinary maintenance operation of the pump must be carried out except by personnel of GemmeCotti or authorized by GemmeCotti. All the operations described in the following paragraphs must be carried out only by suitably qualified personnel and following all the warnings included in this manual step by step.

In the event of routine maintenance of the pump (as indicated in paragraph 4.2) the customer is responsible for the correct disassembly and assembly. The warranty is void in the event of tampering with it, use of non-original parts or in the event of practices that do not comply with what is indicated in this manual.

During routine maintenance of the pump, the customer is responsible for checking the pump tightness (hydrostatic test, taking care to comply with the pump PN), mounting bushings and checking that the pump is functioning properly. To tighten the screws, refer to the table in paragraph 4.8 and be careful not to pinch the O-ring.

Clean the outer surface of the pumps using only antistatic devices.



Any operation carried out on the machine must be carried out only after physically disconnecting the electrical supply.



The handling of pumps with weights greater than 16 kg must not be carried out manually, but only using hoists or other suitable means. When moving the machine or parts of the machine, avoid knocks or falls that could damage the devices.



The bearings of the HVL (pos 15) must be periodically greased using the special nipple (pos 11) visible in the lantern.



Before disassembling pump parts, make sure that hazardous internal liquids have been properly removed/washed. **THE PUMP MUST BE QUENCHED.**



Be aware that some internal liquids may have dangerous reactions when in contact with water.



When discharging hazardous liquids, make sure that there are no situations that pose a danger to people or the environment.

## 4.2 Inspections

Typically, vertical pumps do not require periodic maintenance as they do not require much maintenance. However, periodic inspections are recommended to determine the state of wear of the impeller, shaft and bearings.

The inspection interval is highly dependent on the operating conditions of the pump. The characteristics of the fluid, temperature, materials used and of course the operating time.

If a problem is found or the pump needs a complete inspection, see the "Troubleshooting" and "Pump disassembly" chapters.

### 4.3 HVL Pump Main Parts

Below, the wording Long Version refers to pumps with a length of 1250 mm and above.

#### 4.3.1 Exploded view and Section

The image below shows an exploded view of the main parts making up a pump of the HVL family in thermoplastic material.

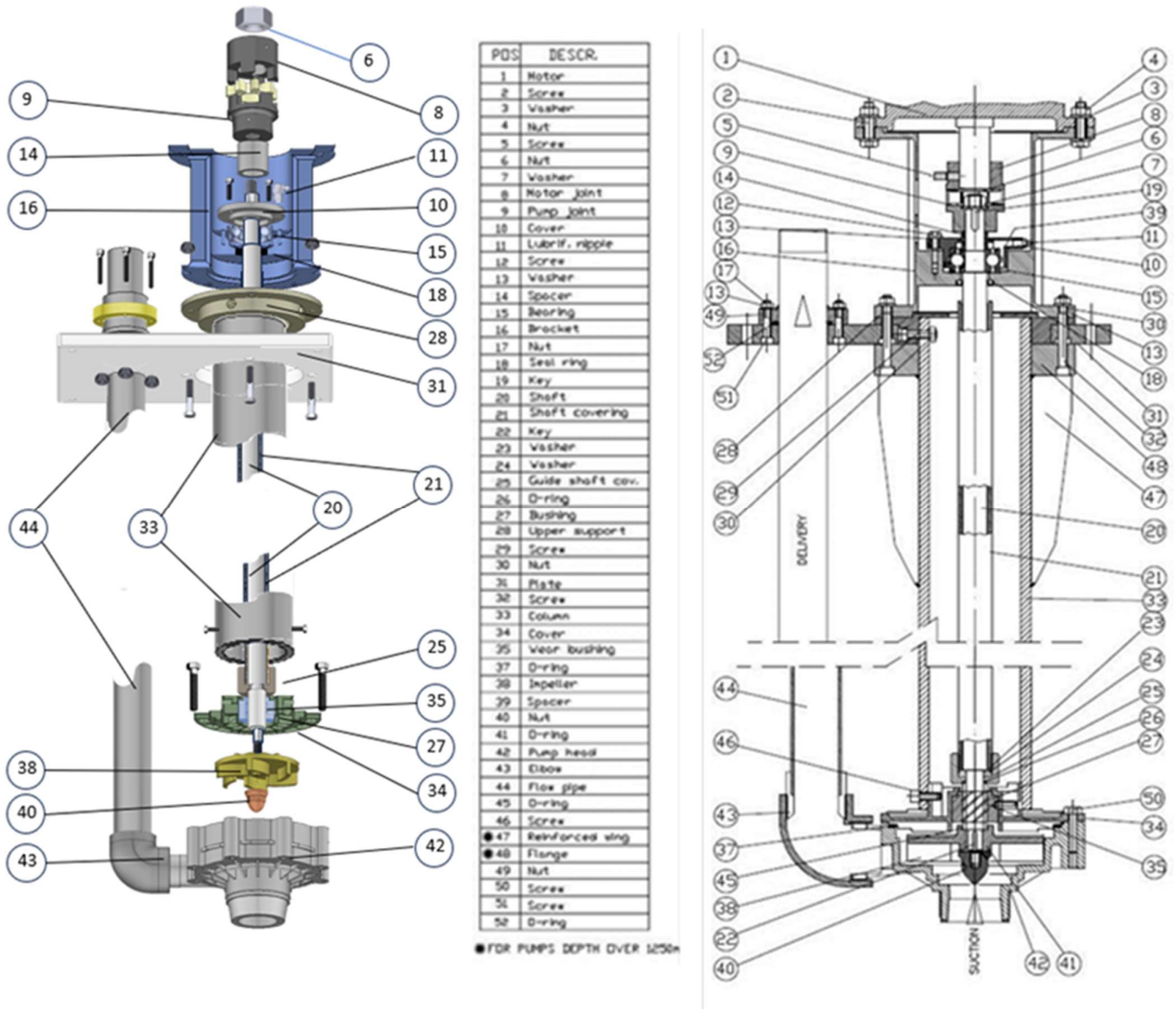

## 4.4 HVL Pump Disassembly

### 4.4.0 Procedure before disassembly



**WARNING:**

If the pump has pumped hot liquids, make sure it has been cooled down before disassembling. The pump may have pumped toxic and/or dangerous liquids, so skin and eye protection should be worn.



**WARNING:**

Be sure that you have thoroughly cleared the pump. Flush and neutralize hazardous fluids inside the pump completely. The liquid must be recovered and disposed of according to existing environmental laws. After disconnecting the suction and delivery hoses, close the ends.

NB: The images used to illustrate the disassembly operations refer to a particular model of the HVL family and therefore the pump supplied with you may slightly differ from what is shown.

### 4.4.1 Disassembling the delivery pipe

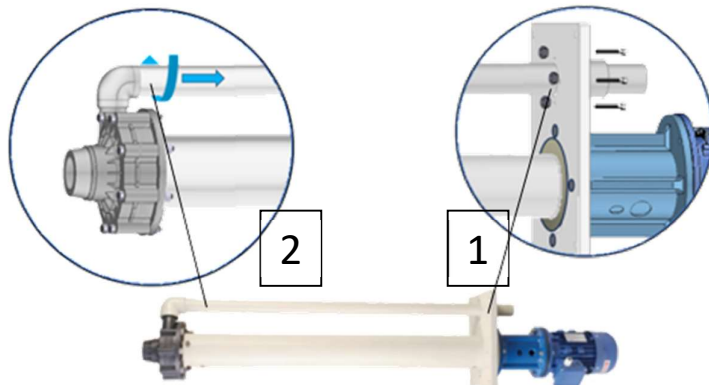

1. Remove the bolts that bind the delivery pipe to the plate
2. Unscrew and remove the delivery hose

### 4.4.2 Motor Disassembly

1. Remove the screws (2) and nuts (4) lift the motor with the semi-elastic coupling (8) on the motor side engaged

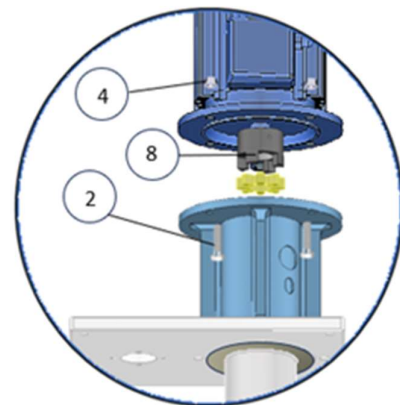

### 4.4.3 Disassembling the pump casing

1-Remove the tightening screws (50) to separate the pump housing (42) from the column cover (34).

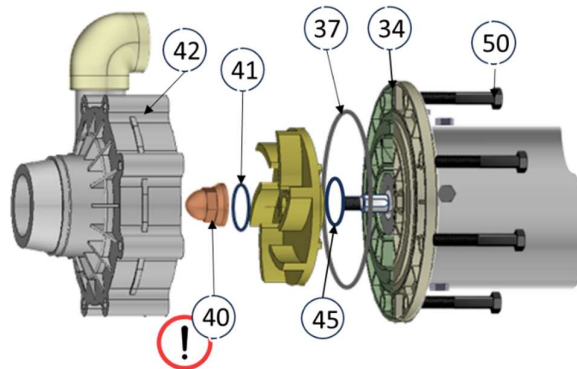

2-Check the O-ring (37) for wear and replace it if necessary. **!** Unscrew the impeller nut using a suitable wrench and a bar to lock the impeller

3-Removed the nut check the condition of the pos O-ring (41) and replace the O-ring if necessary



**WARNING:** the impeller (40) has a left thread, so turn clockwise to unscrew it.

4 Remove the impeller (38), remove the O-ring (45) from the back and replace it if necessary

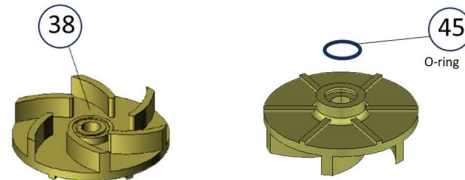

5 Remove the screws (46), and remove the cover (34) with the bushing (27) inside

6 Remove the key (22) and the rotating ceramic bushing (35) and check their condition

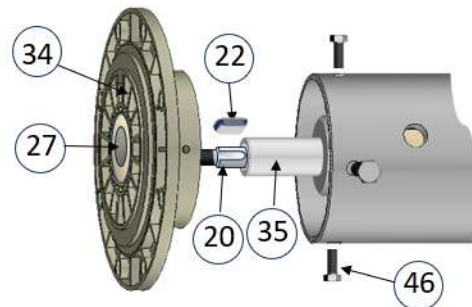

### 4.4.4 Disassembly the shaft with bracket

1. Remove the screws (32) and nuts (30) freeing the bracket and shaft from the plate (31)

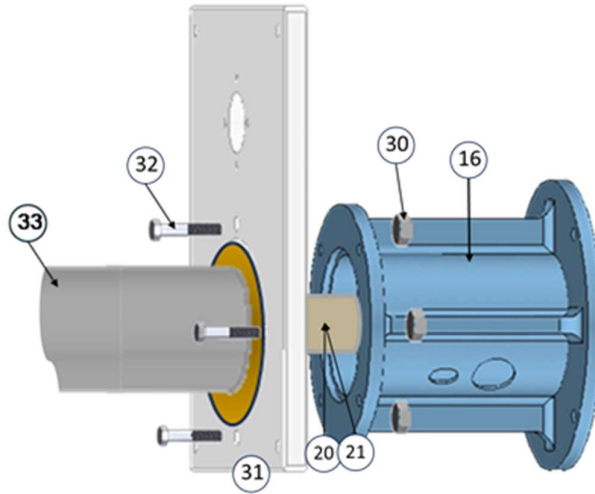

2. Remove the bracket (16) with the shaft (20) and its covering (21) from the column (33)

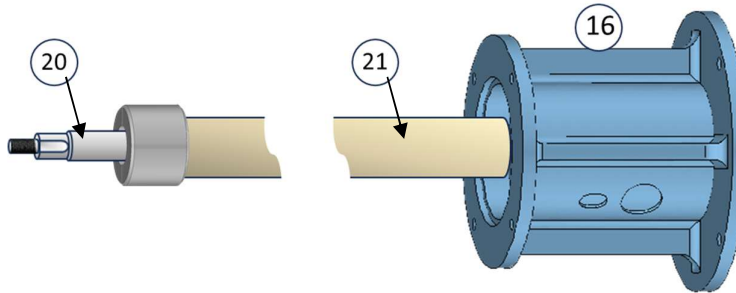

Remove the shaft cover (21) from the shaft (20) with its guide (25) and release the washers (23) and (24)

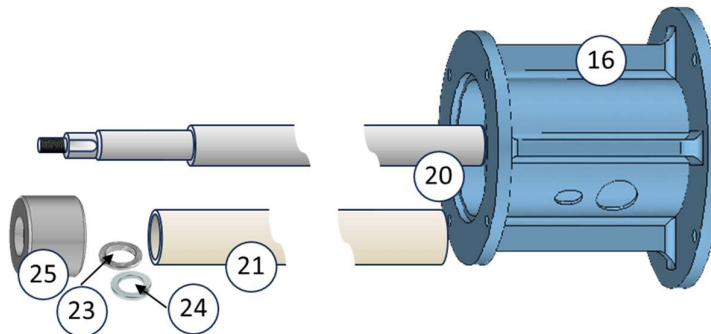

### 4.4.5 Disassembling the shaft from the Bracket

1. Unscrew the nut (6) and remove the shaft side joint (9)
2. Unscrew screws (12) and remove the ball bearing cover (10) with the oiler (11) from the bracket (16)
3. Pull out shaft (20) with bearing (15)
4. Pull the bearing out of the shaft with the help of a puller and check its efficiency
5. Check and replace the lip seal ring if necessary(18).

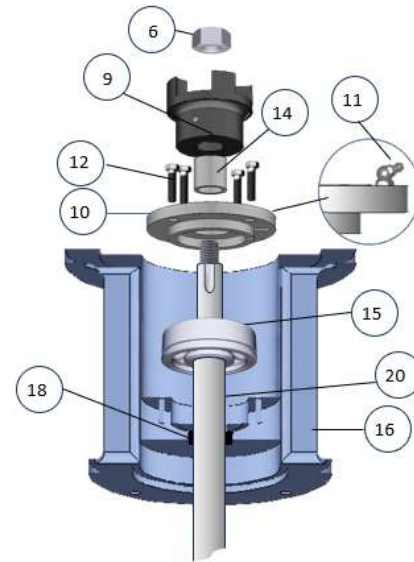

### 4.4.6 Different configuration between versions

Due to the required performance and pump lengths, there are differences in design. These differences are highlighted in an Annex that will be supplied with the pump shipping documents

## 4.5 HVL Mounting

The assembly sequence is mirrored to the disassembly sequence after following the suggestions during disassembly such as O-ring replacement, bushings cleaning, etc.

### 4.5.1 Warnings

Before proceeding with assembly



Clean each component thoroughly before assembly, make sure all parts are free of dirt, metal particles etc

Make sure that when the pump is closed, the gasket (O-ring) is perfectly seated and is not pinched.

use torque wrenches for correct tightening force of the screws according to the table in paragraph 4.6 below

### 4.5.2 Mounting Shaft with Bracket

Follow the sequences shown in point 4.4.4 from the reassembly of the shaft with bearing on the bracket to the reassembly of the shaft lining to the fixing of the bracket with the shaft on the Plate

### 4.5.3 Pump Body Assembly

Follow the steps listed in point 4.4.3 backwards by making the suggested substitutions.



**WARNING** : after mounting the elbow 43 to the pump outlet, be careful to orient everything by aligning the elbow with the delivery hole of the plate 31

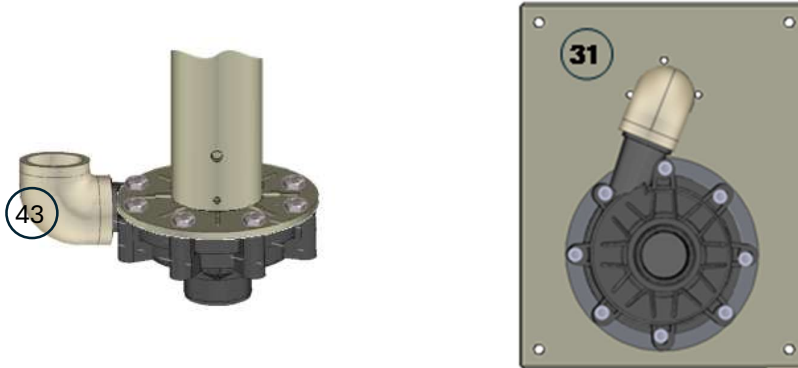

### 4.5.4 Discharge pipe assembly

Follow the steps highlighted in point 4.4.1 backwards

### 4.5.6 Motor Mounting

Follow the steps highlighted in point 4.4.2 backwards



If you are replacing the motor, make sure that the characteristics of the motor are the same as the motor being replaced. The manufacturer of the motor may be different from the one previously fitted.



After tightening the pump onto the motor flange, momentarily remove the protective fan shield on the rear of the motor and rotate the fan by hand to verify the free rotation of the assembled assembly. If excessive friction or abnormal noise is detected, proceed to disassemble the assembly (operations in paragraph 4.4) and to detect the cause of the anomaly. Under no circumstances should the pump be used without having carried out this check. Reassemble the protective fan before starting the pump.

## 4.6 HV Pump Main Parts

Below, reference is made to the generic HV series pump. The HV 140 pump has an adapter flange between the motor and the plate compared to the others.

### 4.6.1 Exploded view and Section

The image below shows an exploded view of the main parts making up the pump of the HV family in thermoplastic material.

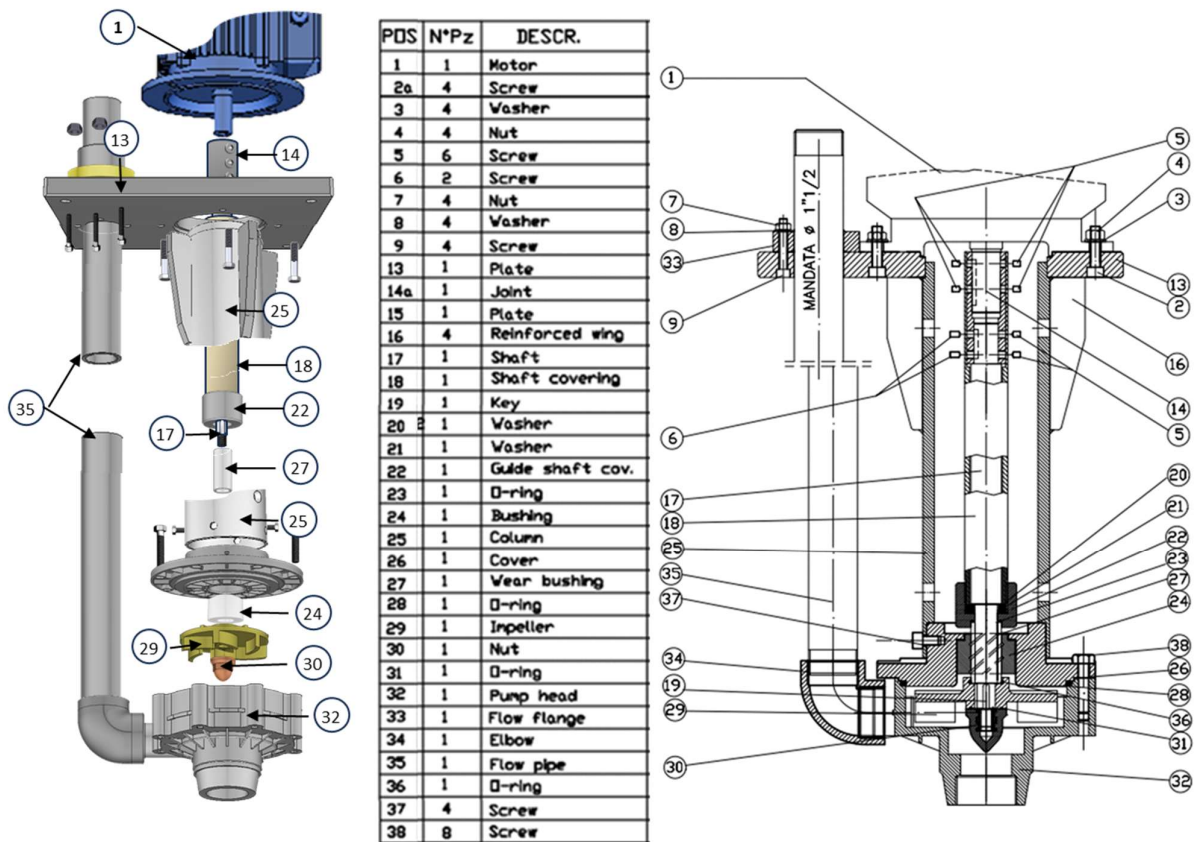

## 4.7 HV Pump Disassembly

### 4.7.0 Procedure before disassembly



**WARNING:**

If the pump has pumped hot liquids, make sure it has been cooled down before disassembling. The pump may have pumped toxic and/or dangerous liquids, so skin and eye protection should be worn.



**WARNING:**

Be sure that you have thoroughly cleared the pump. Flush and neutralize hazardous fluids inside the pump completely. The liquid must be recovered and disposed of according to existing environmental laws. After disconnecting the suction and delivery hoses, close the ends.

**4.7.1 Disassembling the delivery pipe**

1. Remove the bolts that bind the delivery pipe to the plate
2. Unscrew and remove the delivery hose

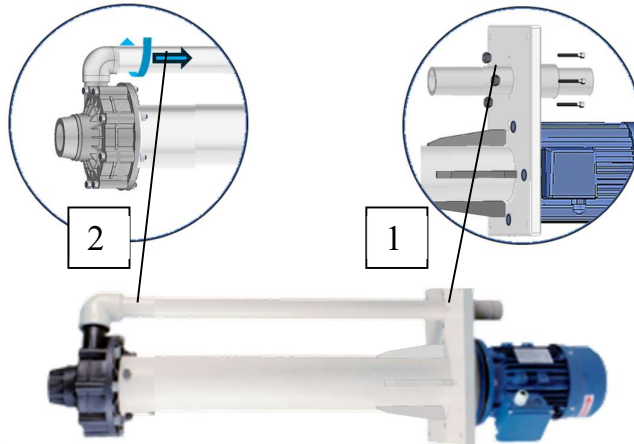

**4.7.2 Disassembling the pump casing**

- 1-Remove** the screws (38) to separate the pump housing (32) from the column cover (26).
- 2-Check** the wear of the pos O-ring (28) and replace it if necessary. Unscrew the impeller nut (30) using a suitable wrench and a bar to lock the impeller
- 3-Removed** the nut check the condition of the O-ring (31) and replace it if necessary

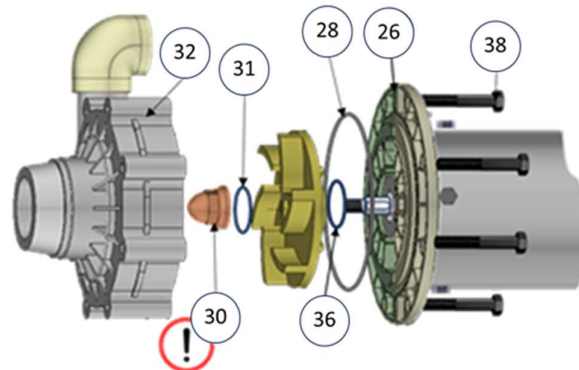

**WARNING:** The impeller nut (40) has the left thread, so turn clockwise to unscrew it.



- 4** Remove the impeller (29), remove the o-ring (36) from the back and replace it if necessary

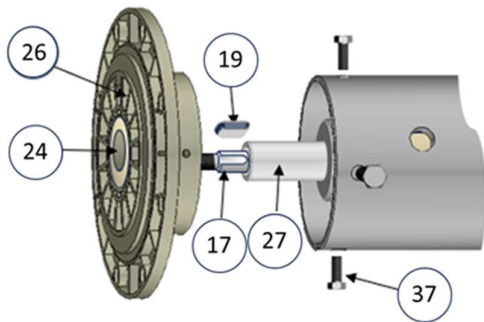

**5** Remove the screws (37), and remove the cover (26) with the bushing (24) inside

**6** Remove the key (19) and the rotating ceramic bushing (27) and check their condition

### 4.7.3 Motor and shaft disassembly

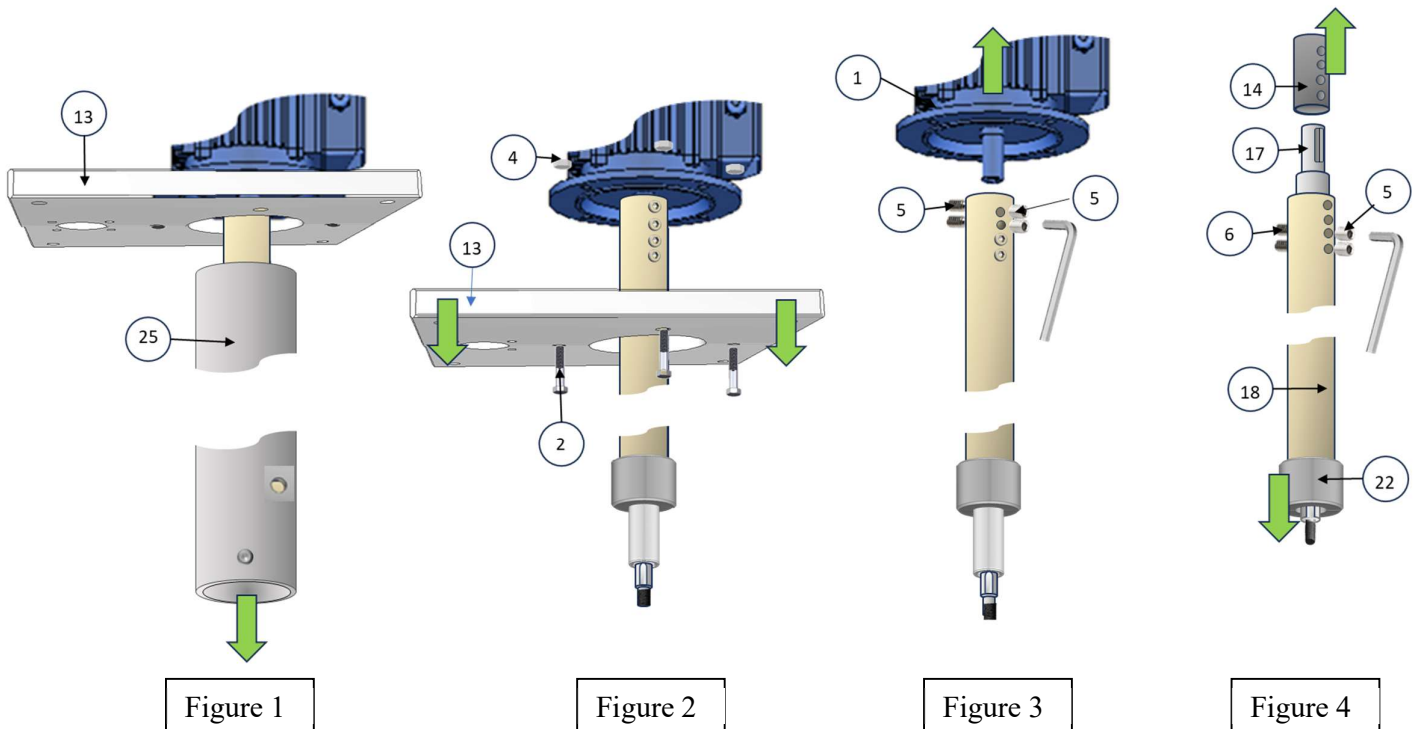

1. Separate the column (25) from the plate (13) (Figure 1)
2. Unscrew the screws (2) from the nuts (4) to remove the plate 13 (Figure 2)
3. Unscrew the 4 Allen grub screws (5) of the upper part to free and remove the motor (1)
4. Unscrew the grub screws (5) and the two Allen grub screws (6) to free the shaft (17) from the shaft cover (18) with its guide (22) and pull out the coupling (14) (Figure 4)

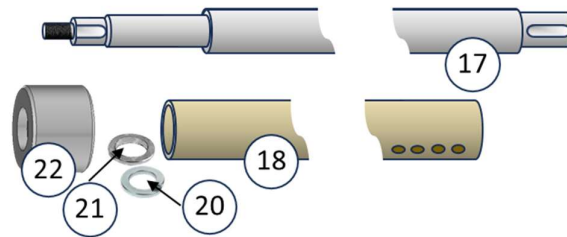

Figure 5

5. Remove the shaft cover (18) from the shaft (17) with its guide (22) and release the washers (21) and (20)

## 4.8 HV Mounting

The assembly sequence is mirrored to the disassembly sequence after following the suggestions during disassembly such as O-ring replacement, bushings cleaning, etc.

### 4.8.1 Warnings

Before proceeding with assembly



Clean each component thoroughly before assembly, make sure all parts are free of dirt, metal particles etc

Make sure that when the pump is closed, the gasket (O-ring) is perfectly seated and is not pinched.

use torque wrenches for correct tightening force of the screws according to the table in paragraph 4.6 below

### 4.8.2 Shaft Mounting with Motor

Follow the sequences shown in point 4.7.3 from Figure 5 backwards to Figure 1



If you are replacing the motor, make sure that the characteristics of the motor are the same as the motor being replaced. The manufacturer of the motor may be different from the one previously fitted.



After tightening the pump onto the motor flange, momentarily remove the protective fan shield on the rear of the motor and rotate the fan by hand to verify the free rotation of the assembled assembly. If excessive friction or abnormal noise is detected, proceed to disassemble the assembly (operations in paragraph 4.4) and to detect the cause of the anomaly. Under no circumstances should the pump be used without having carried out this check. Reassemble the protective fan before starting the pump.

### 4.8.3 Pump casing assembly

Follow the steps listed in point 4.7.2 backwards by making the suggested substitutions.

### 4.8.4 Discharge Pipe Assembly

Follow the steps highlighted in point 4.7.1 backwards



**ATTENTION** : after mounting the elbow 43 to the pump outlet, be careful to orient everything by aligning the elbow with the delivery hole of the plate 31

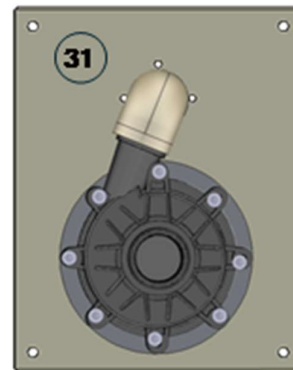
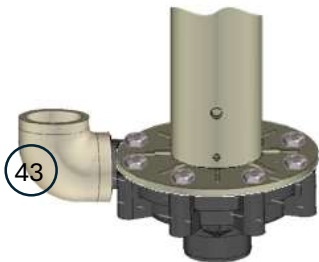

## 4.9 Tightening Torques

The recommended tightening torques are shown below.

AISI SCREWS (A2 – A4)	COUPLING TYPE	
	PLASTIC / PLASTICPLASTIC / METAL	METAL / METAL
M5	3 Nm	8 Nm
M6	6 Nm	13 Nm
M8	10 Nm	32 Nm
M10	17 Nm	65 Nm
M12	25 Nm	110 Nm
M16	50 Nm	290 Nm

## 5. TROUBLESHOOTING

Motor overload Insufficient flow velocity or pressure Lack of pressure on the delivery side Uneven output pressure flow Noise and vibration Pump plugged Pump over heating Blade around wear Leak in the pump										Problem	Possible cause	Solution									
										•	Incorrect direction of rotation of the motor	Reverse the direction of rotation									
										•	•	•	•							Insufficient suction (NPSHa)	•Increase NPSH availability •Increase suction reserve (positive head) •Lower pump •Increase suction hose diameter •Shorten or make suction hose direct
										•	The pump is clogged	Clean the pump									
										•	•	•								Cavitation	Increase the available suction NPSH
										•	•	•								The pump sucks in air	Check that the joints of the suction pipes are tight
										•	•	•								The suction hose is blocked	Check valves and filters on the suction line
										•		•								Pressure delivered too strong	Reduce thrust by increasing pipe diameter and/or reducing the number of valves and bends
										•		•	•							Flow velocity too high	•Partially close the pressure valve •Reduce the rotational speed
										•		•	•	•	•					Liquid temperature too high	Cool the liquid
																		•		Incorrect material of the o-ring x the pumped liquid	Fit an O <sub>2</sub> ring of different material (contact us)
										•		•	•	•						Impeller rubs	•Reduce the temperature •Adjust the distance between the impeller and the beaker or body
												•	•	•	•					Foreign objects in the liquid	Cool the liquid
												•								Closing the valve on the suction side	Check open the valve
										•										Discharge pressure too low	Increase the pressure: install impeller with larger diameter (contact Gemme Cotti)

## 6. SPARE PARTS

### 6.1 How to Order Spares

A complete series of spare parts is available from our warehouse and our distributors. To request spare parts, you must provide the model of your pump, the size, the material, the serial number, the year of construction and the number of the spare part required. These references can be found directly on the pump plate and on the cross-section drawings relating to the pump itself. If you do not have the drawings in the section, contact the GemmeCotti sales office (tel. +39 0296460406).

## 7. DATA

### 7.1 Characteristic curves

#### HVL PUMPS

#### CURVE 50HZ - 2900 RPM

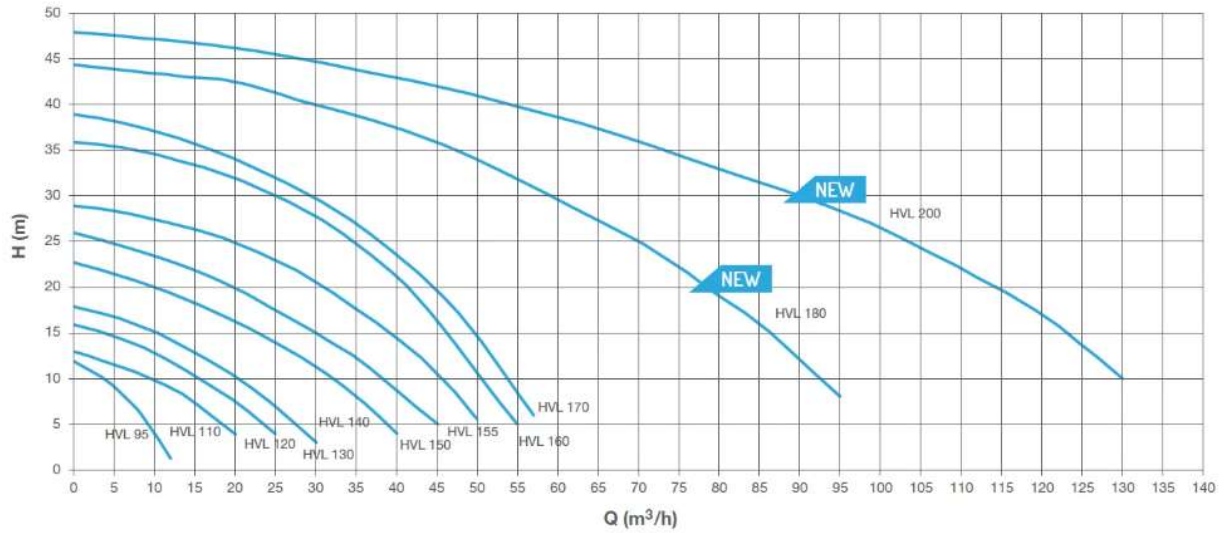

#### HV PUMPS

#### PERFORMANCE CURVES 50Hz - 2900 RPM

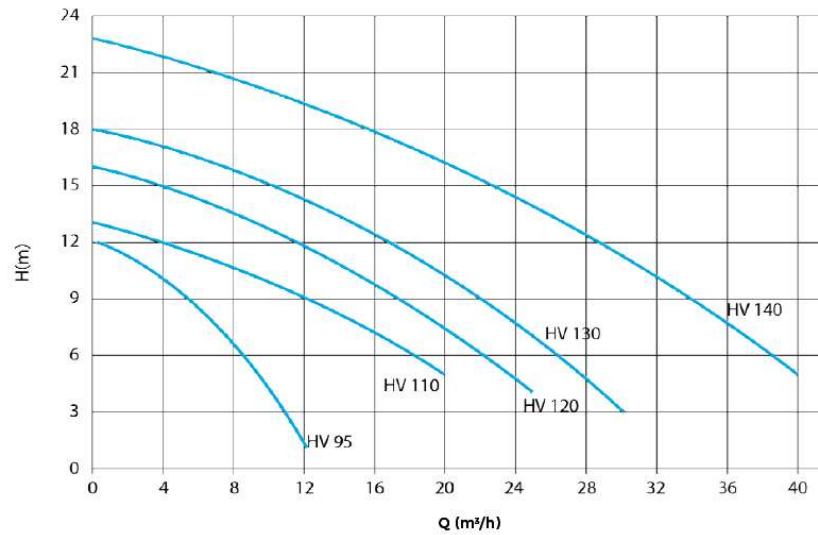



### 7.2.2 HVL Vertical with Coupling Pumps

## HVL 95 - 110 - 120 - 130 - 140 PP/PVDF DIMENSIONI

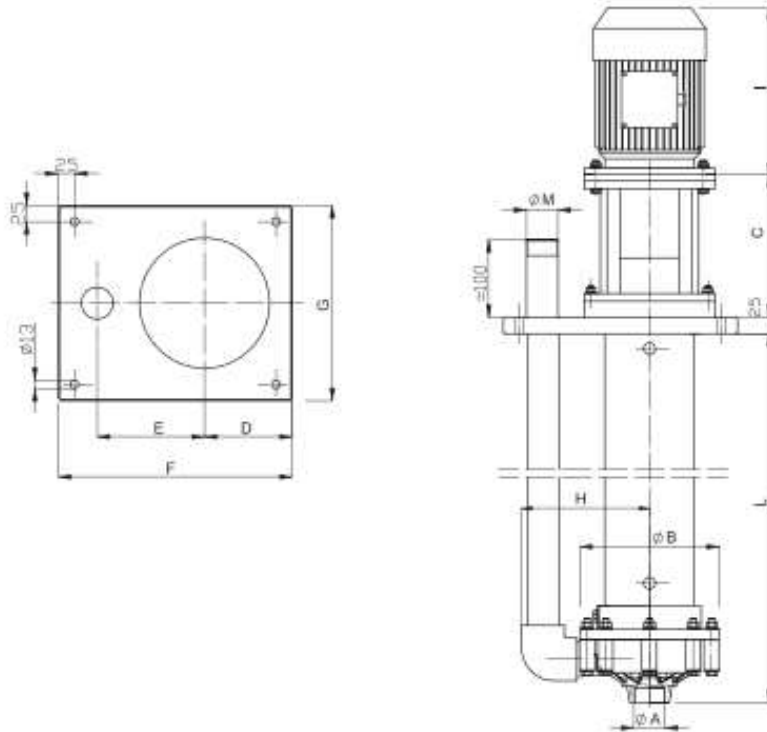

POMPA	MOTORE BS	KW	DIMENSIONI - mm -										
			ØA	ØM	ØB	C	D	E	F	G	H	I	L
HVL 95	G 80	0,75	2" F	1 1/2" M	215	210	135	165	360	300	196	215	A richiesta da 500 a 2000 mm
HVL 110	G 80	1,1				210	230						
HVL 120	G 90 S	1,5				220	255						
HVL 130	G 90 L	2,2				230	280						
HVL 140	G 100	3				230	315						
HVL 140	112 M	4				230	337						

# HVL 150 - 155 - 160 - 170 - 180 - 200 PP/PVDF

## DIMENSIONI

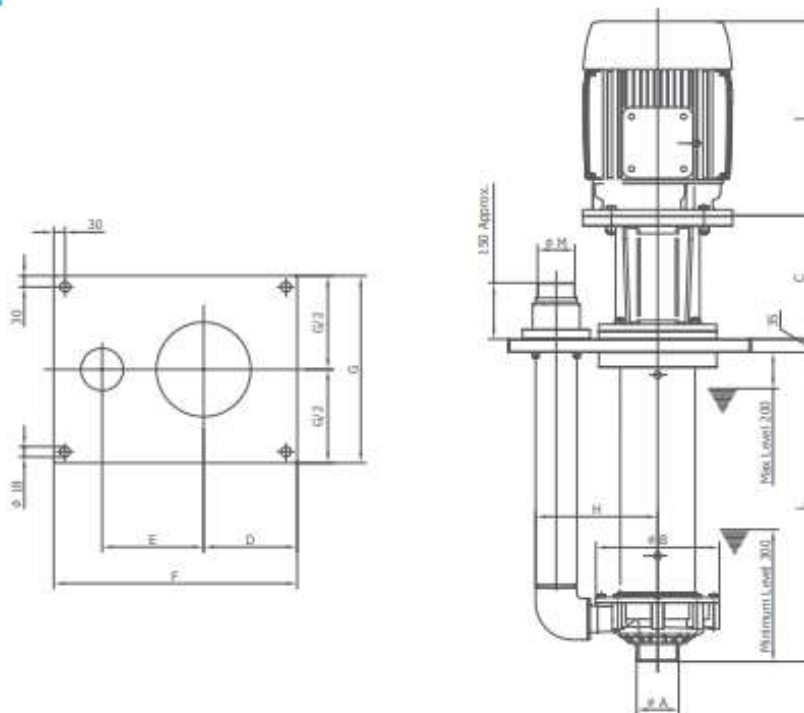

POMPA	MOTORE BS	Kw	DIMENSIONI - mm -										
			ØA	ØM	ØB	C	D	E	F	G	H	I*	L
HVL 150	6 132 SA	5,5	3" M	2" M	275	265	170	215	480	380	260	380	A richiesta da 500 a 2000 mm
HVL 150	132 SB	7,5											
HVL 155	6 132 SA	5,5											
HVL 155	132 SB	7,5											
HVL 160	6 132 SB	7,5											
HVL 160	132 MA	9,2											
HVL 170	6 132 SB	9											
HVL 180	180 M	11	4" M	3-1/2" M	330	330	250	271	650	500	325	531	
HVL 180	180 M	22										645	
HVL 200	200 L	37										760	

## 7.3 Technical data and limitations

The specific curves are valid for homogeneous fluids with specific gravity = 1, viscosity 1cPs at temperature 20°C. If liquids with a specific gravity greater than 1 are to be pumped, the absorbed power shown on the characteristic curve must be multiplied by the value of the specific gravity of the liquid to be pumped. For liquids with a specific gravity greater than 2, contact the technical service of GemmeCotti s.r.l. (tel. +390296460406).

The characteristic curves are valid for homogeneous liquids with a viscosity of 1 CPS. If the pumped liquid has viscosity other than 1 CPS, the Q/H values will be altered. The efficiency of the pump will decrease. For liquids with a viscosity of less than 0.5 CPS or higher than 150 CPS, please contact the GemmeCotti technical service.

The required NPSH values shown on the characteristic curves are the lowest required values. As a rule, for safety reasons, the NPSH value of the system must be at least 0.5 m higher than the required NPSH value (shown on the characteristic curves).

The efficiency values shown on the curves refer to sample pumps in the prototyping phase. In pumps built in series, these values may be lower. As a rule, these values should be considered reduced as follows:

- Pumps with discharge connection up to 25 mm: -3 points
- Pumps with a delivery connection greater than 25 mm: -2 points

The characteristics of HVL pumps are guaranteed by the manufacturer with tolerances in accordance with the UNI EN ISO 9906:2002 standards – Hydraulic performance tests and acceptance criteria. Compliance with other specifications or regulations requiring tighter tolerances must be specifically requested at the time of the request for quotation; in this case, the most suitable pump will be selected and the required regulations will be considered accordingly.

## 8. WARRANTY AND REPAIR

### 8.1 Warranty

All GemmeCotti srl products are covered by warranty for a period of twelve (12) months starting from the date of delivery of the goods.

In order to obtain the warranty, it is necessary that the defect is reported in writing within 8 days of when it occurs, and that the part intended for repair or replacement is sent to GemmeCotti. No warranty is exercised on site. In the event of a warranty claim, it is preferable to return the complete pump with motor to GemmeCotti.

Transport costs and related risks, and any customs charges, are borne by the buyer and shipments will not be accepted in any way at the expense of the recipient.

The Manufacturer is not responsible for any damage caused during the transport of the parts or the pump, sent for warranty intervention.

The warranty system provides that, following a careful examination at our headquarters, GemmeCotti will proceed at its discretion to repair or replace the part (or parts) of the pump that demonstrates the presence of defects or defects in the material or workmanship, or both. There is no refund or credit for defective material or for direct or indirect damage, including loss of production, caused by our pumps. In any case, any claim may not exceed the cost of the pump or the material supplied.

If the pumped liquid and the required performance have not been communicated during the request for quotation, and confirmed by GemmeCotti during the offer and order confirmation phase, the customer assumes total responsibility for the use of the product, which may be used improperly, and consequently the warranty, the declaration of conformity to the Machinery Directive 2006/42/EC and the related CE marking will be void. In this case, the customer assumes responsibility for placing the product on the market and must draw up a new declaration of conformity and mark the pump. The user is however considered the greatest connoisseur of the chemical compatibility and reactions between the liquid to be pumped and the construction materials of the pump, therefore the information provided in this regard by GemmeCotti is purely indicative.

If the returned product is no longer covered by the warranty, or if no defect or defect is found following the examination, the buyer will be charged the inspection costs and the repaired or replaced product will be returned at the expense of the recipient. Pumps repaired or replaced under warranty, on the other hand, will be supplied under the same return conditions as the main order and the warranty will not be extended.

The warranty does not apply to components subject to normal wear and tear, such as mechanical seals, bearings, bushings and lip seals.

The purchaser is solely responsible for the proper use of the pump and its thorough maintenance. Consequently, the warranty will not be applied to pumps that have been poorly stored (not stored in a closed and dry place, necessary by virtue of the delicacy of the materials purchased), contaminated, handled negligently, incorrectly installed, tampered with or poorly adjusted, improperly used in the wrong applications and/or conditions. Specifically, GemmeCotti assumes no responsibility in the event of wear caused by corrosion.

Ordinary repairs and/or maintenance carried out outside the authorized GemmeCotti network will void the warranty and the CE declaration.

The warranty also does not cover damage caused by extraordinary and/or natural events, such as lightning, frost, fire, etc.

The warranty obligations are considered fully satisfied with the repair or replacement of defective parts. The warranty provided will be suspended in the event of non-payment, or delay, and the uncovered period will not be recovered.

This warranty clause is an integral part of the offer and the order confirmation.

The competent court for any disputes is the Court of Busto Arsizio.

## 8.2 Parts Returns and Repairs

All our distributors have a complete repair service. Contact your local distributor or directly with GemmeCotti srl.

Before returning a pump to our repair services or directly to GemmeCotti the pumps must be reclaimed of the hazardous liquids used. Before returning the pump, the customer must send a declaration of remediation by e-mail as per the facsimile in paragraph 8.3 below.

## 8.3 Declaration of remediation <sup>5</sup> (facsimile)

Att.

**GemmeCotti *European Pumps***

Via Po 23/25/27 – 20031 Cesate (mi)

Telephone 02. 964. 60. 406-Fax 02. 964. 69. 114

Date.....

SUBJECT: Declaration of Pump Reclamation for Overhaul

With reference to our DDT n° ..... of..... We hereby want to confirm that the fluid treated with these pumps is:

.....

The pump has been cleaned up by us, which is why there is no precaution or warning, you can proceed with the inspection without any danger.

Sincerely

STAMP AND SIGNATURE

<sup>5</sup> TO BE COMPLETED ON THE CUSTOMER'S LETTERHEAD

### 8.4 CE Certificate for HV-HVL Series Pumps

**Declaration of conformity** <sup>6</sup> (facsimile)  
to the Machinery Directive 2006/42/EC

**GEMMECOTTI srl**  
**Office and Workshop.:** Via PO 23/25/27  
20031 CESATE (MI)  
**Registered Office:** P.zza De Gasperi 15  
21040 Gerenzano (VA)

We declare under our sole responsibility that the pump:

Brand: GEMMECOTTI

Type:

Model:

r:

Year:

As described in the attached documentation, it complies with the Machinery Directive 2006/42 EC (ex 89/392/EEC - 91/368/EEC - 93/44/EEC - 93/68/EEC - 98/37 EEC) only if used with the liquids communicated by the customer and for the characteristics required of the pump in relation to order No. .... of.....

If the pumped liquid and the required performance have not been communicated, the customer assumes full responsibility for the use of the product used improperly.

Compliance with these requirements is expressed through the marking



ENRICO GEMME  
(General Manager)  
Cesate, .....

Signature

<sup>6</sup> In cases where the customer does not communicate the type of liquid used in the pump and the expected operating conditions, the EC Declaration of Conformity will not be issued and the customer will assume the responsibility and burden of providing for the Certification of the pump in its application.